

# DUST COMMANDER® S60

High performance cyclone filter element / Dust collector

Sulaco A.I.R Works 1 ROUTE DE BERGHEIM • Z.A Sud • 67600 SELESTAT • FRANCE • info@dust-commander.com • +33 (0) 950 911 805

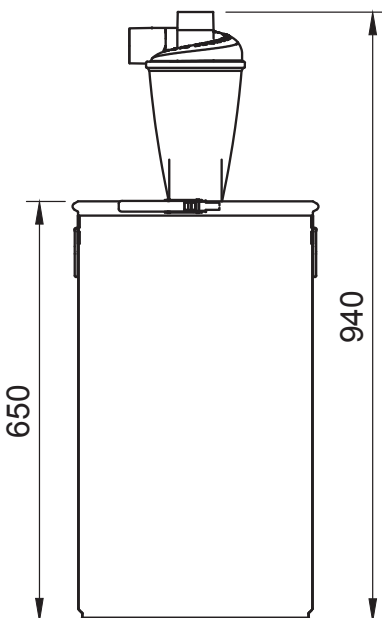
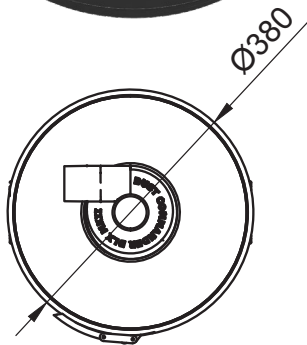

## Reference

DUST-S60

## Description

- Kit version of the DUST COMMANDER DLX ESD pre-mounted on a black steel drum
- High efficiency pre-filter (>99%)
- Anti-static
- Compatible with shop vacs and ring blowers up to 2.2kW

## Scope of delivery

- 1 x pre mounted DUST COMMANDER DLX FILTER
- 1 x 60 liter capacity steel drum (black paint finish)
- 2 x 40mm adapters (only for units shipped after 03/2021)
- 2 x 35mm adapters
- 2 x 32mm adapters

## Max air flow

240m<sup>3</sup>/h

## Build material

30% glass filled ESD polyamid (PA30GF) with surface resistivity < 1E6 ohms/square - black color / Drum : carbon steel - black color

## COO

France

## HS CODE

8421392090

## EAN

3760013430474

## Height

94 cm

## Width

38 cm

## Depth

38 cm

## Weight

5.71 kg

## Packing dimensions

71 x 42 x 41 cm

## Packing Weight

9.8 kg