

DUST COMMANDER® X30

Industrial cyclone filter element / Dust collector

Sulaco A.I.R Works 1 ROUTE DE BERGHEIM • Z.A Sud • 67600 SELESTAT • FRANCE • info@dust-commander.com • +33 (0) 950 911 805

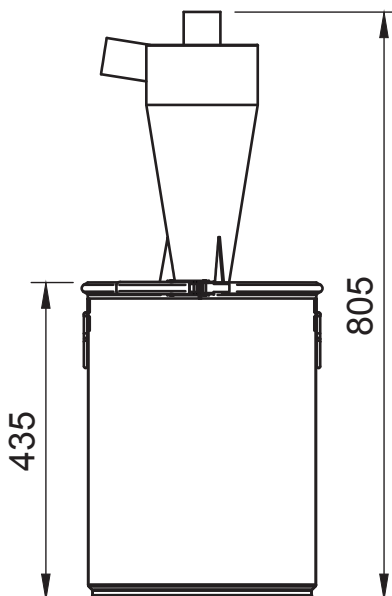
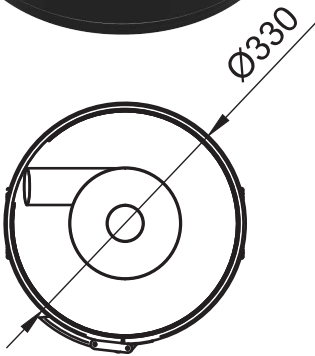

Reference

DUST-X30

Description

- Kit version of the DUST COMMANDER HD with a black steel drum
- High efficiency cyclone separator (>99%)
- Heavy duty industrial construction
- 50mm (outer) diameter input/output ports
- Compatible with shop vacs and ring blowers up to 3.0kW

Scope of delivery

- 1 x DUST COMMANDER HD filter
- 1 x 30 liter capacity steel drum (black paint finish) with pre-cut lid
- 1 x MOUNTING KIT includes :
 - 6 x ISO 7380F M5x12 stainless steel A2 hex button head socket screw with flange
 - 6 x DIN 9021 M5 (5.3) stainless steel A2 washers
 - 6 x DIN 934 M5 stainless steel A2 nuts
 - 1 x closed cell polyethylene foam gasket

Max air flow

300m³/h

Build material

Filter : carbon steel – satin matt paint finish / Drum : carbon steel - black color

COO

France

HS CODE

8421392090

EAN

3760013430061

Height

80.5 cm

Width

33 cm

Depth

33 cm

Weight

5.24 kg

Packing dimensions

1 unit : 58 x 40 x 39 cm / 2 units : 70 x 49 x 36 cm / 4 units : 71 x 71 x 49 cm

Packing Weight

1 unit : 7.4 kg / 2 units : 13.3 kg / 4 units : 26 kg